

SANDELL'S MASONRY REGLETS

Product Name:
Sandell®'s Masonry Reglets

Product Description:
Sandell®'s Masonry Reglet is a reliable way to terminate roofing, waterproofing, and flashing in concrete walls.

Use:
Use Sandell®'s Masonry Reglets at parapet walls and above shelf angels, lintels and ledges.

Installation:
Nail to inside face of concrete forms. Use double-headed nails to resist damage when forms are stripped. Roofing or flashing is typically secreted in reglet with lead wedges, resilient rod stock or sealants.

- Technical Information:**
- ❖ Standard size - 26G 1" and 1/2" flanges with 1/4" lips for adhering to concrete.
 - ❖ Opening is 1/2" x 1-3/4" deep at a 65° angle into the wall.
 - ❖ Standard length is 10 feet.

- Available in:**
- ❖ Stainless Steel
 - ❖ Mil Galvanized.

- Stainless Steel:**
- ❖ Sheet Metal anchors and ties -
 - ❖ ASTM A 167 AISI Type 304

- Mil Galvanized:**
- ❖ Sheet Metal anchors and ties -
 - ❖ ASTM A 653 G60
 - ❖ Wire: ASTM A 641 (0.1 oz/ft²)

Warranty:
Sandell's Masonry Reglet carries a manufacturer's warranty of material specification compliance.

Maintenance:
Sandell's Masonry Reglet should not require maintenance if installed in accordance with Sandell specifications and instructions.

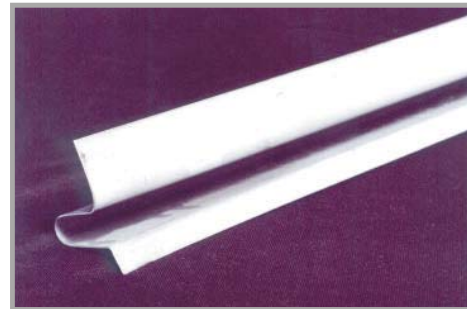
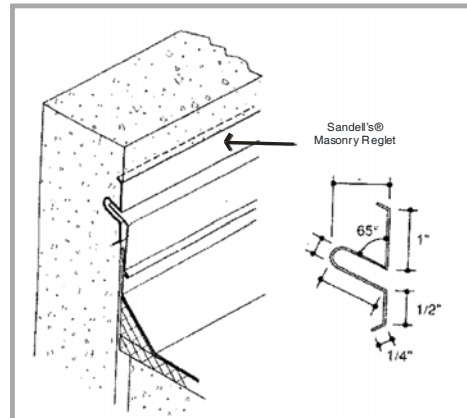

TECHNICAL ASSISTANCE:
Call Sandell directly for technical assistance or product questions:
New York: 800.283.3888
Alabama: 877.726-3355
Wisconsin: 800.323-3565

 www.sandellmfg.com

Amendments / Notes:

--	--

Sandell Employee:

Date:

**CORPORATE OFFICE
NEW YORK
Toll Free: 800-283-3888
Fax: 518-357-9757**

**BRANCH OFFICE
ALABAMA
Toll Free: 877-SANDELL
Fax: 205-263-1033**

**BRANCH OFFICE
WISCONSIN
Toll Free: 800-323-3565
Fax: 414-764-6993**